

ZAGZAVOD ZA
GRADBENIŠTVO
SLOVENIJESLOVENIAN
NATIONAL BUILDING
AND CIVIL ENGINEERING
INSTITUTE

Član

Member of



www.eota.eu

**Dimičeva 12,
1000 Ljubljana, Slovenija**

Tel.: +386 (0)1 280 44 72, +386 (0)1-280 45 37

Fax: +386 (0)1 280 44 84

e-mail: info.ta@zag.si

http://www.zag.si

European Technical Assessment

**ETA-18/0219
of 10.10.2018***English version prepared by ZAG*

GENERAL PART

**Organ za tehnično ocenjevanje, ki je izdal
ETA***Technical Assessment Body issuing the ETA***ZAG Ljubljana****Komercialno ime gradbenega proizvoda
Trade name of the construction product****EJOT through bolts
BA-V Plus/ BA-F Plus/ BA-E Plus/ BA-E
Plus HCR****Družina proizvoda****33: Torzijsko kontrolirano ekspanzijsko
sidro velikosti M8, M10 in M12 za
vgradnjo v beton***Product family to which the construction product belongs***33: Torque controlled expansion anchor sizes M8,
M10 and M12 for use in concrete****Proizvajalec
Manufacturer****EJOT BAUBEFESTIGUNGEN GmbH
In der Stockweise 35
57334 BAD LAASPHE
Germany**

www.ejot.com

**Proizvodni obrat
Manufacturing plant****EJOT Plant 14****Ta Evropska tehnična ocena vsebuje***This European Technical Assessment contains***15 strani vključno s 12 prilogami, ki so
sestavni del te ocene
15 pages including 12 annexes, which form an integral
part of the document****Ta Evropska tehnična ocena je izdana na
podlagi Uredbe (EU) št. 305/2011 na osnovi
This European Technical Assessment is issued in
accordance with Regulation (EU) No 305/2011, on the
basis of****EAD 330232-00-0601, izdaja oktober 2016****EAD 033232-00-0601, edition October 2016****Ta verzija zamenjuje
This version replaces****ETA-16/0934 izdano dne 16.07.2018****ETA-16/0934 issued on 16.07.2018**

Translations of this European Technical Assessment in other languages shall fully correspond to the original issued document and should be identified as such.

Communication of this European Technical Assessment, including transmission by electronic means, shall be in full (excepted the confidential Annex(es) referred to above). However, partial reproduction may be made, with the written consent of the Issuing Technical Assessment Body. Any partial reproduction has to be identified as such.

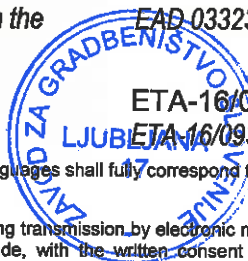

SPECIFIC PART OF THE EUROPEAN TECHNICAL ASSESSMENT

1 Technical description of the product

The EJOT through bolts BA-V Plus/ BA-F Plus/ BA-E Plus/ BA-E Plus HCR is an anchor made of zinc plated carbon steel (BA-V Plus), hot dip galvanized carbon steel (BA-F Plus), stainless steel (BA-E Plus) and high corrosion resistant stainless steel (BA-E Plus HCR). It consists of a bolt, expansion sleeve, hexagonal nut and washer.

Anchors are made in sizes M8, M10 and M12. Anchor is placed into a drilled hole and anchored by torque-controlled expansion.

For the installed anchor see Figure given in Annex A1.

2 Specification of the intended use(s) in accordance with the applicable European Assessment Document (hereinafter EAD)

The performances given in Chapter 3 are only valid if the anchor is used in compliance with the specifications and conditions given in Annex B.

The provisions made in this European Technical Assessment are based on an assumed working life of the anchor of 50 years. The indications given on the working life cannot be interpreted as a guarantee given by the manufacturer, but are to be regarded only as a means for choosing the right products in relation to the expected economically reasonable working life of the works.

3 Performance of the product and references to the methods used for its assessment

3.1 Mechanical resistance and stability (BWR 1)

The basic work requirements for mechanical resistance and stability are listed in Annexes C1 and C2.

3.2 Safety in case of fire (BWR 2)

The basic work requirements for safety in case of fire are listed in Annexes C3 and C4.

3.3 Hygiene, health and environment (BWR 3)

Regarding dangerous substances contained in this European Technical Assessment, there may be requirements applicable to the products falling within its scope (e.g. transported European legislation and national laws, regulations and administrative provisions). In order to meet provisions of the regulation (EU) No 305/2011, these requirements need also to be complied with, when they apply.

3.4 Safety in use (BWR 4)

For basic work requirement safety in use the same criteria are valid as for basic work requirement mechanical resistance and stability.

3.5 Protection against noise (BWR 5)

Not relevant.

3.6 Energy economy and heat retention (BWR 6)

Not relevant.

3.7 Sustainable use of natural resources (BWR 7)

No performance assessed.

3.8 General aspects relating to fitness for use

Durability and serviceability are only ensured if specifications of intended use according to Annex B1 are kept.



4 Assessment and verification of constancy of performance (hereinafter AVCP) system applied, with reference to its legal base

According to the decision 96/582/EC of the European Commission¹ the system of assessment and verification of constancy of performance (see Annex V to regulation (EU) No 305/2011) 1 apply.

5 Technical details necessary for the implementation of the AVCP system, as provided for on the applicable EAD

5.1 Tasks for the manufacturer

Technical details necessary for the implementation of the AVCP system are laid down in chapter 3 of EAD 330232-00-0601.

Issued in Ljubljana on 10.10.2018

Signed by:

Franc Capuder, M.Sc., Research Engineer
Head of Service of TAB

EJOT through bolt

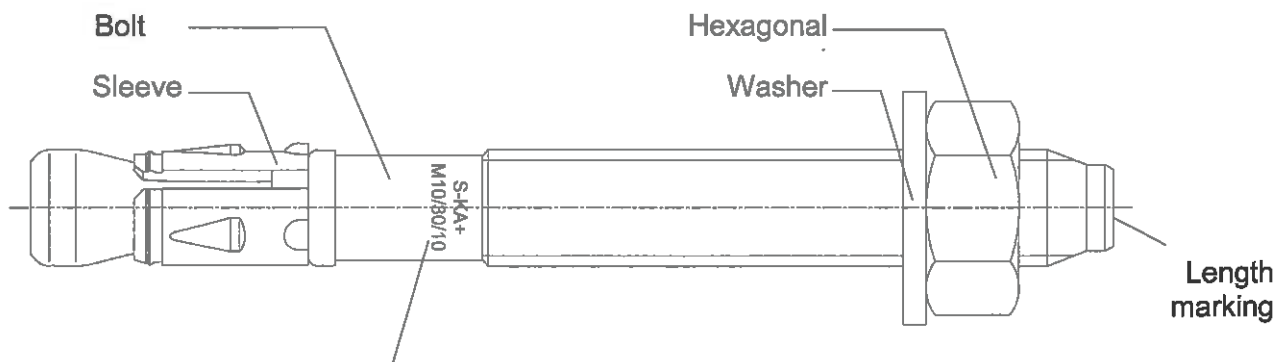

Marking:

BA-V Plus:	S-KA+ M.../t _{fix,max} /t _{fix,min}	- zinc plated
BA-F Plus:	S-KAK+ M.../t _{fix,max} /t _{fix,min}	- hot dip galvanized
BA-E Plus:	S-KAH+ M.../t _{fix,max} /t _{fix,min}	- stainless steel A4
BA-E Plus HCR:	S-KAH+ HCR M.../t _{fix,max} /t _{fix,mi}	- high corrosion resistant stainless steel

Length marking:

Length marking	A	B	C	D	E	F
Length (mm)	38,1-50,8	50,8-63,5	63,5-76,2	76,2-88,9	88,9-101,6	101,6-114,3

Length marking	G	H	I	J	K
Length (mm)	114,3-127,0	127,0-139,7	139,7-152,4	152,4-165,1	165,1-177,8

Length marking	L	M	N	O	P
Length (mm)	177,8-190,5	190,5-203,2	203,2-215,9	215,9-228,6	228,6-241,3

Length marking	Q	R	S
Length (mm)	241,3-254,0	254,0-279,4	279,4-304,8

**EJOT through bolt BA-V Plus/ BA-F Plus/
BA-E Plus /BA-E Plus HCR**

Product description
Product

Annex A1



EJOT through bolt after installation

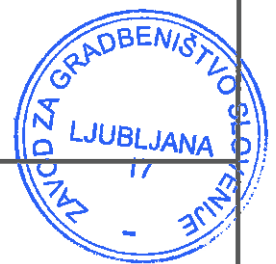
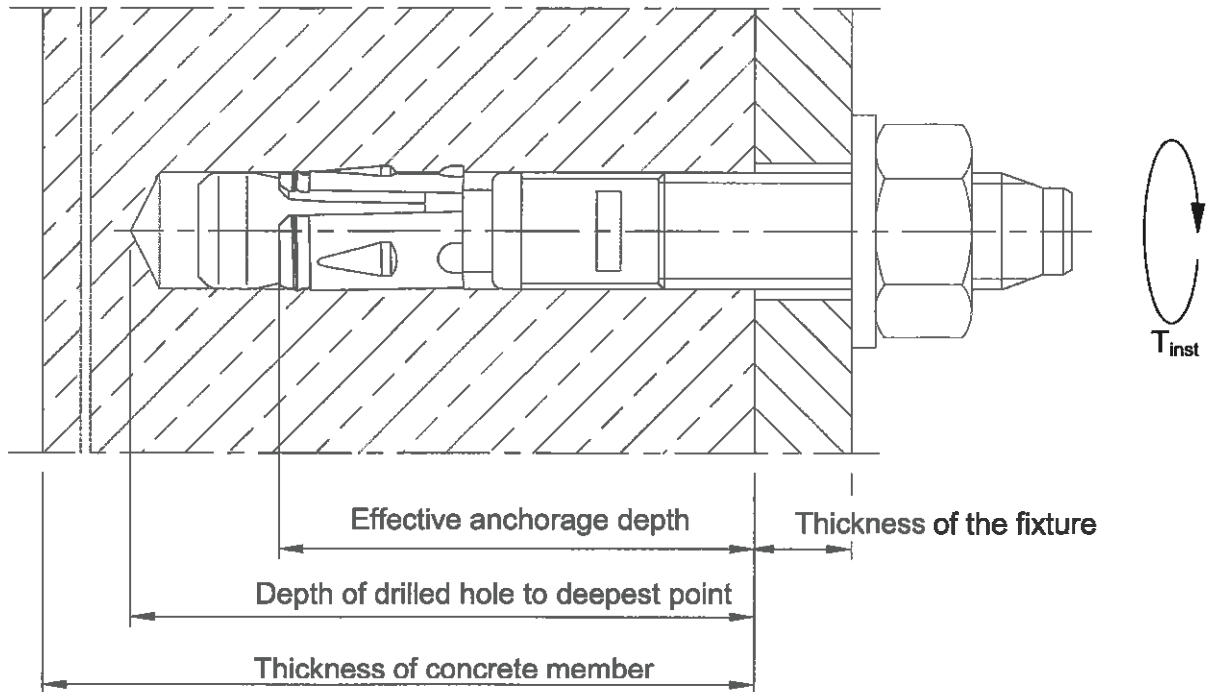

**EJOT through bolt BA-V Plus/ BA-F Plus/
BA-E Plus /BA-E Plus HCR**

Product description
Installation condition

Annex A2

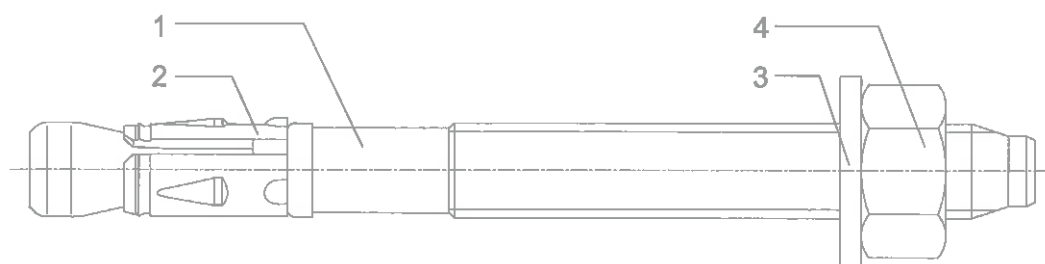
EJOT through bolt**Table A1: Materials for BA-V Plus and BA-F Plus**

Part	Designation	Material ^{1) 2)}
1	Bolt	Cold forged carbon steel, EN 10263-2
2	Sleeve	Cold rolled galvanized steel strip, EN 10346 or stainless strip, EN 10088-2
3	Washer	Steel, DIN 125 (EN ISO 7089), DIN 440 (EN ISO 7094), DIN 9021 (EN ISO 7093)
4	Hexagonal nut	Steel, electroplated, property class 8, DIN 934 (EN ISO 4032)

¹⁾ **BA-V Plus:** Parts 1,3 and 4 are zinc electroplated according to EN ISO 4042 $\geq 5\mu\text{m}$ and bright passivated

²⁾ **BA-F Plus:** Parts 1,3 and 4 are hot dip galvanized according to EN ISO 10684

Table A2: Materials for BA-E Plus

Part	Designation	Material
1	Bolt	Cold forged stainless steel, EN 10088-3
2	Sleeve	Stainless steel strip, EN 10088-2
3	Washer	Stainless steel, DIN 125 (EN ISO 7089), DIN 440 (EN ISO 7094), DIN 9021 (EN ISO 7093)
4	Hexagonal nut	Stainless steel, property class 80, DIN 934 (EN ISO 4032)

Table A3: Materials for BA-E Plus HCR

Part	Designation	Material
1	Bolt	Cold forged stainless steel, EN 10088-3 1.4529/1.4565
2	Sleeve	Stainless steel strip, EN 10088-2
3	Washer	Stainless steel, W 1.4529 / 1.4565, DIN 125 (EN ISO 7089), DIN 440 (EN ISO 7094), DIN 9021 (EN ISO 7093)
4	Hexagonal nut	Stainless steel, property class 70, W 1.4529 / 1.4565, DIN 934 (EN ISO 4032)

**EJOT through bolt BA-V Plus/ BA-F Plus/
BA-E Plus /BA-E Plus HCR**

**Product description
Materials**

Annex A3

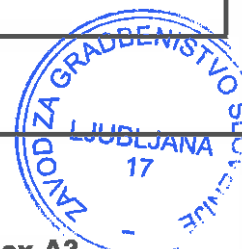

Specifications of intended use

Anchorage subjected to:

- Static, quasi static load.
- Fire exposure.

Base materials:

- Cracked and non-cracked concrete.
- Reinforced and unreinforced normal weight concrete of strength class C20/25 at minimum and C50/60 at maximum according to EN 206:2013+A1:2016.

Use conditions (Environmental conditions):

- The BA-V Plus and BA-F Plus anchors may be used in concrete subject to dry internal conditions.
- The BA-E Plus anchors may be used in concrete subject to dry internal conditions and also in concrete subject to external atmospheric exposure (including industrial and marine environment), or exposure in permanently damp internal conditions, if no particular aggressive conditions exist.
- The BA-E Plus HCR anchors may be used in concrete subject to dry internal conditions and also in concrete subject to external atmospheric exposure, in permanently damp internal conditions or in other particular aggressive conditions.

Note: Particular aggressive conditions are e.g. permanent, alternating immersion in seawater or the splash zone of seawater, chloride atmosphere of indoor swimming pools or atmosphere with extreme chemical pollution (e.g. desulphurization plants or road tunnels where de-icing materials are used).

Design:

- Anchorages are designed under the responsibility of an engineer experienced in anchorages and concrete work.
- Anchorages under static and quasi-static actions are designed in accordance with EOTA TR 055, Edition December 2016 or FprEN 1992-4:2016.
- For application with resistance under fire exposure the anchorages are designed in accordance with the method given in EOTA TR 020, Edition May 2004.
- Verifiable calculation notes and drawings are prepared taking into account of the load to be anchored. The position of the anchor is indicated on the design drawings (e.g. position of the anchor relative to reinforcement or to supports, etc.).

Installation:

- Anchor installation carried out by appropriately qualified personnel and under the supervision of the person responsible for technical matters on the site.
- Use of the anchor only as supplied by the manufacturer without exchanging the components of an anchor.
- Anchor installation in accordance with the manufacturer's specifications and drawings using the appropriate tools.
- Checks before placing the anchor to ensure that the strength class of the concrete in which the anchor is to be placed is in the range given and is not lower than that of the concrete to which the characteristic loads apply for.
- Check of concrete being well compacted, e.g. without significant voids.
- Cleaning of the hole of drilling dust.
- Anchor installation ensuring the specified embedment depth.
- Keeping of the edge distance and spacing to the specified values without minus tolerances.
- In case of aborted hole, drilling of new hole at a minimum distance of twice the depth of the aborted hole, or smaller distance provided the aborted drill hole is filled with high strength non-shrinkage mortar. No shear or oblique tension loads are allowed in the direction of a not filled aborted hole.
- Application of the torque moment given in Annex B2 using a calibrated torque wrench.

**EJOT through bolt BA-V Plus/ BA-F Plus/
BA-E Plus /BA-E Plus HCR**

**Intended use
Specifications**

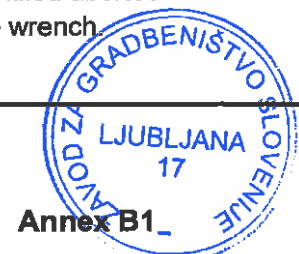

Annex B1

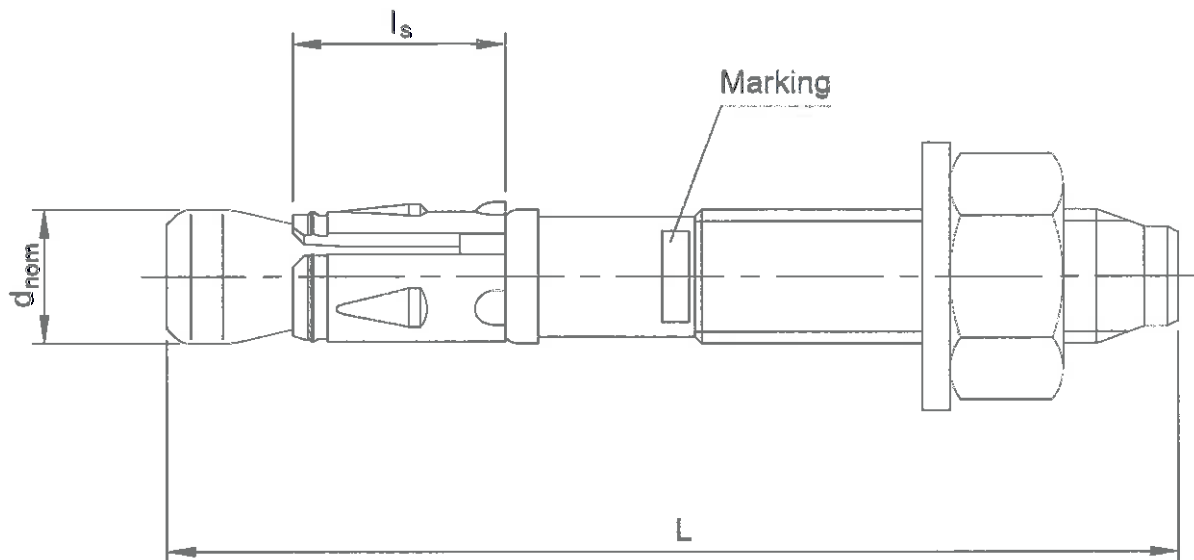
EJOT through bolt**Table B1:** Dimension of an anchor

Size	Nominal diameter d_{nom} [mm]	Sleeve length l_s [mm]	Total length L [mm]
M8	8	14,8	62 ... 420
M10	10	17,9	62 ... 420
M12	12	19,1	78 ... 420

**EJOT through bolt BA-V Plus/ BA-F Plus/
BA-E Plus /BA-E Plus HCR**

Intended use
Anchor dimensions

Annex B2

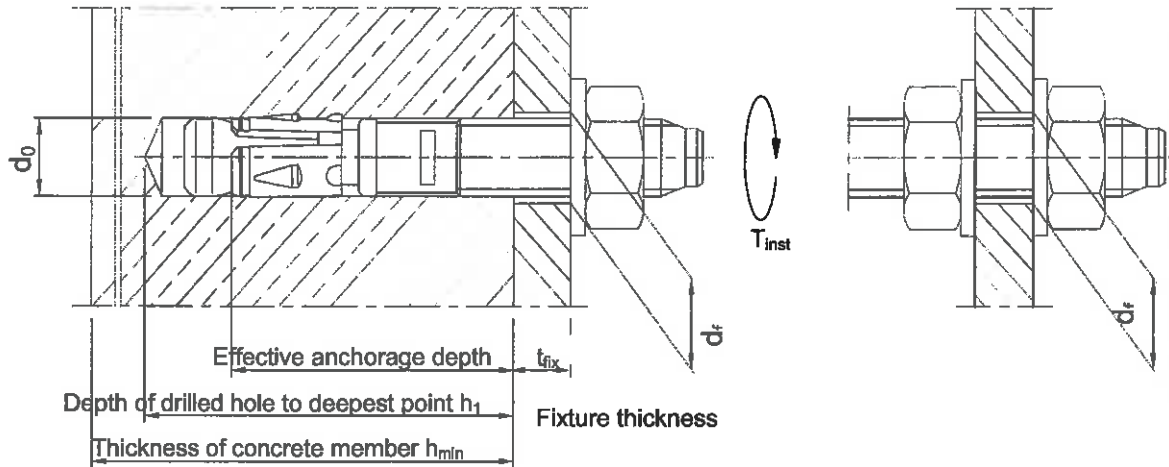

**Table B2: Installation data**

EJOT through bolt BA-V Plus/ BA-F Plus/ BA-E Plus / BA-E Plus HCR		Anchor size				
		M8	M10- red	M10	M12- red	M12
Drill hole diameter	d_0 [mm]	8	10	10	12	12
Cutting diameter at the upper tolerance limit (maximum diameter bit)	$d_{cut,max} \leq$ [mm]	8,45	10,45	10,45	12,50	12,50
Depth of drilled hole to deepest point	$h_1 \geq$ [mm]	60	55	75	70	90
Effective anchorage depth	h_{ef} [mm]	48	40	60	50	70
Diameter of clearance hole in the fixture	$d_f \leq$ [mm]	9	12	12	14	14
Thickness of the fixture	$t_{fix,max}$ [mm]	358	358	338	342	322
Required torque BA-V Plus/BA-F Plus BA-E Plus / BA-E Plus HCR	T_{inst} [Nm]	15	30	30	60	60
		20	45	45	60	60



**EJOT through bolt BA-V Plus/ BA-F Plus/
BA-E Plus /BA-E Plus HCR**

Intended use
Installation data

Annex B3

Table B3: Minimum thickness of concrete member, spacing and edge distance

EJOT through bolt BA-V Plus/ BA-F Plus/ BA-E Plus / BA-E Plus HCR		Anchor size				
		M8	M10- red	M10	M12- red	M12
Minimum thickness of concrete member	h_{min} [mm]	100	100	120	100	140
	$h_{min-red}$ [mm]	80	/	100	/	/
Minimum spacing for h_{min}	s_{min} [mm]	35	50	40	55	60
	$c \geq$ [mm]	50	95	60	110	70
Minimum edge distance for h_{min}	c_{min} [mm]	40	50	50	60	55
	$s \geq$	55	190	100	215	110
Minimum spacing for $h_{min-red}$	s_{min} [mm]	35	/	40	/	/
	$c \geq$ [mm]	55	/	100	/	/
Minimum edge distance for $h_{min-red}$	c_{min} [mm]	40	/	60	/	/
	$s \geq$	60	/	90	/	/

**EJOT through bolt BA-V Plus/ BA-F Plus/
BA-E Plus /BA-E Plus HCR**

Intended use
Installation data

Annex B4



Table C1: Characteristic resistances under tension loads in case of static and quasi-static loading for design according EOTA TR 055 or **EN 1992-4:2016**

EJOT through bolt BA-V Plus/ BA-F Plus/ BA-E Plus / BA-E Plus HCR				Anchor size				
				M8	M10- red	M10	M12- red	M12
Steel failure								
Characteristic resistance	BA-V Plus/ BA-F Plus	$N_{Rk,s}$	[kN]	15	26	26	39	39
	BA-E Plus / BA-E Plus HCR			15	26	26	40	40
Partial safety factor		$\gamma_{Ms}^{2)}$	[-]	1,4				
Pull-out failure								
Characteristic resistance in cracked concrete C20/25		$N_{Rk,p}$	[kN]	8,5	¹⁾	12	¹⁾	16
Characteristic resistance in non-cracked concrete C20/25		$N_{Rk,p}$	[kN]	11	12	19	¹⁾	25
Increasing factor for $N_{Rk,p}$		ψ_c	C25/30	1,09	1,12	1,07	1,12	1,11
			C30/37	1,17	1,22	1,13	1,22	1,21
			C35/45	1,23	1,32	1,17	1,32	1,29
			C40/50	1,30	1,41	1,23	1,41	1,38
			C45/55	1,37	1,50	1,28	1,50	1,46
			C50/60	1,43	1,58	1,33	1,58	1,53
Partial safety factor		$\gamma_{inst}^{2)}$	[-]	1,0				
		$\gamma_{Mp}^{3)}$	[-]	1,5 ³⁾				
Concrete cone and splitting failure								
Effective anchorage depth		h_{ef}	[mm]	48	40	60	50	70
Factor for cracked concrete		k_{cr}	[-]	7,7				
Factor for non-cracked concrete		k_{ucr}	[-]	11,0				
Spacing		$s_{cr,N}$	[mm]	144	120	180	150	210
Edge distance		$c_{cr,N}$	[mm]	72	60	90	75	105
Spacing (splitting)		$s_{cr,sp}$	[mm]	192	160	240	200	280
Edge distance (splitting)		$c_{cr,sp}$	[mm]	96	80	120	100	140
Partial safety factor		$\gamma_{Msp}^{2)}$	[-]	1,5				

¹⁾ Pull-out failure is not decisive

²⁾ In absence of other national regulations

³⁾ The installation safety factor of $\gamma_2 = 1,0$ is included

EJOT through bolt BA-V Plus/ BA-F Plus/
BA-E Plus /BA-E Plus HCR

Performance
Characteristic resistance under tension loads

Annex C1

LJUBLJANA
17



Table C2: Characteristic resistances under shear loads in case of static and quasi-static loading for design according to EOTA TR 055 or **FprEN 1992-4:2016**

EJOT through bolt BA-V Plus/ BA-F Plus/ BA-E Plus / BA-E Plus HCR				Anchor size				
				M8	M10- red	M10	M12- red	M12
Steel failure without lever arm								
Characteristic resistance	BA-V Plus/ BA-F Plus	$V_{Rk,s}$	[kN]	12,6	18,4	18,4	28,7	28,7
	BA-E Plus / BA-E Plus HCR			15,8				
Partial safety factor		$\gamma_{Ms}^{1)}$	[-]	1,25				
Factor for considering ductility		k_2	[-]	1,0				
Steel failure with lever arm								
Characteristic resistance	BA-V Plus/ BA-F Plus	$M_{Rk,s}^0$	[Nm]	26,3	50	50	86	86
	BA-E Plus / BA-E Plus HCR			25,1				
Partial safety factor		$\gamma_{Ms}^{1)}$	[-]	1,25				
Concrete pryout failure								
k-factor		$k_{(3)}$	[-]	1,0	1,0	2,0	1,0	2,0
Partial safety factor		$\gamma_{Mc}^{1)}$	[-]	1,5				
Concrete edge failure								
Effective length of anchor under shear load		l_f	[mm]	48	40	60	50	70
Outside diameter of anchor		d_{nom}	[mm]	8	10		12	
Cracked concrete without any edge reinforcement		$\Psi_{ucr,V}$	[-]	1,0				
Cracked concrete with straight edge reinforcement > Ø12 mm				1,2				
Cracked concrete with edge reinforcement and closely spaced stirrups ($a \leq 100\text{mm}$) or non-cracked concrete				1,4				
Partial safety factor		$\gamma_{Mc}^{1)}$	[-]	1,5				

¹⁾ In absence of other national regulations

**EJOT through bolt BA-V Plus/ BA-F Plus/
BA-E Plus /BA-E Plus HCR**

Performance

Characteristic resistance under shear loads

Annex C2



Table C3: Characteristic resistances under tension loads in case of fire exposure for design according to EOTA TR 020 or **EN 1992-4:2016**

EJOT through bolt BA-V Plus/ BA-F Plus/ BA-E Plus / BA-E Plus HCR				Anchor size				
				M8	M10- red	M10	M12- red	M12
Steel failure								
Characteristic resistance $N_{Rk,s,fi}$	BA-V Plus/ BA-F Plus	R30	[kN]	0,22	0,56	0,56	1,12	1,12
		R60	[kN]	0,20	0,48	0,48	0,84	0,84
		R90	[kN]	0,16	0,37	0,37	0,73	0,73
		R120	[kN]	0,11	0,30	0,30	0,56	0,56
	BA-E Plus / BA-E Plus HCR	R30	[kN]	0,45	0,93	0,93	1,73	1,73
		R60	[kN]	0,36	0,74	0,74	1,45	1,45
		R90	[kN]	0,27	0,59	0,59	1,16	1,16
		R120	[kN]	0,22	0,52	0,52	0,93	0,93
Pull-out failure								
Characteristic resistance $N_{Rk,p,fi}$	R30	[kN]	2,13	1)	3,00	1)	4,00	
	R60	[kN]	2,13	1)	3,00	1)	4,00	
	R90	[kN]	2,13	1)	3,00	1)	4,00	
	R120	[kN]	1,70	1)	2,40	1)	3,20	
Concrete cone and splitting failure ²⁾								
Characteristic resistance $N_{Rk,c,fi}^0$	R30	[kN]	2,87	1,82	5,02	3,18	7,38	
	R60	[kN]	2,87	1,82	5,02	3,18	7,38	
	R90	[kN]	2,87	1,82	5,02	3,18	7,38	
	R120	[kN]	2,30	1,46	4,02	2,55	5,90	
Spacing	$s_{cr,N,fi}$	[mm]	4 x h_{ef}					
	s_{min}	[mm]	35	50	40	55	60	
Edge distance	$c_{cr,N,fi}$	[mm]	2 x h_{ef}					
	c_{min}	[mm]	Fire attack from one side: $c_{min} = 2 \times h_{ef}$ Fire attack from more than one side: $c_{min} \geq 300 \text{ mm}$ and $\geq 2 \times h_{ef}$					

1) Pull-out isn't decisive

2) As a rule, splitting failure can be neglected when cracked concrete and reinforcement is assumed

Design under fire exposure is performed according to the design method given in EOTA TR 020.

Under fire exposure usually cracked concrete is assumed. The design equations are given in EOTA TR 020 § 2.2.1.

In the absence of other national regulations the partial safety factor for resistance under fire exposure $\gamma_{M,fi} = 1,0$ is recommended.

**EJOT through bolt BA-V Plus/ BA-F Plus/
BA-E Plus /BA-E Plus HCR**

Performance

Characteristic tension resistance under fire exposure

Annex C3



Table C4: Characteristic resistances under shear loads in case of fire exposure for design according to EOTA TR 020 or **FprEN 1992-4:2016**

EJOT through bolt BA-V Plus/ BA-F Plus/ BA-E Plus / BA-E Plus HCR				Anchor size				
				M8	M10- red	M10	M12- red	M12
Steel failure without lever arm								
Characteristic resistance $V_{Rk,s,fi}$	BA-V Plus/ BA-F Plus	R30	[kN]	0,22	0,56	0,56	1,12	1,12
		R60	[kN]	0,20	0,48	0,48	0,84	0,84
		R90	[kN]	0,16	0,37	0,37	0,73	0,73
		R120	[kN]	0,11	0,30	0,30	0,56	0,56
	BA-E Plus / BA-E Plus HCR	R30	[kN]	0,45	0,93	0,93	1,73	1,73
		R60	[kN]	0,36	0,74	0,74	1,45	1,45
		R90	[kN]	0,27	0,59	0,59	1,16	1,16
		R120	[kN]	0,22	0,52	0,52	0,93	0,93
Steel failure with lever arm								
Characteristic resistance $M^0_{Rk,s,fi}$	BA-V Plus/ BA-F Plus	R30	[Nm]	0,38	1,12	1,12	2,62	2,62
		R60	[Nm]	0,34	0,97	0,97	1,97	1,97
		R90	[Nm]	0,26	0,75	0,75	1,70	1,70
		R120	[Nm]	0,19	0,60	0,60	1,31	1,31
	BA-E Plus / BA-E Plus HCR	R30	[Nm]	0,75	1,87	1,87	3,93	3,93
		R60	[Nm]	0,60	1,50	1,50	3,28	3,28
		R90	[Nm]	0,45	1,20	1,20	2,62	2,62
		R120	[Nm]	0,38	1,05	1,05	2,10	2,10
Concrete pryout failure								
k-factor	$k_{(3)}$	[-]	1,0	1,0	2,0	1,0	2,0	
Characteristic resistance $V_{Rk,cp,fi}$	R30	[kN]	2,87	1,82	10,04	3,18	14,76	
	R60	[kN]	2,87	1,82	10,04	3,18	14,76	
	R90	[kN]	2,87	1,82	10,04	3,18	14,76	
	R120	[kN]	2,30	1,46	8,04	2,55	11,80	
Concrete edge failure								
The initial value $V^0_{Rk,c,fi}$ of the characteristic resistance in concrete C20/25 to C50/60 under fire exposure may be determined by:								
$V^0_{Rk,c,fi} = 0,25 \times V^0_{Rk,c} \quad (\leq R90) \quad \quad V^0_{Rk,c,fi} = 0,20 \times V^0_{Rk,c} \quad (R120)$								
with $V^0_{Rk,c}$ initial value of the characteristic resistance in cracked concrete C20/25 under normal temperature.								

Design under fire exposure is performed according to the design method given in EOTA TR 020.

Under fire exposure usually cracked concrete is assumed. The design equations are given in EOTA TR 020 § 2.2.1.

EOTA TR 020 covers design for fire exposure from one side. For fire attack from more than one side the edge distance must be increased to $c_{min} \geq 300$ mm and $\geq 2 \times h_{ef}$.

In the absence of other national regulations the partial safety factor for resistance under fire exposure $\gamma_{M,fi} = 1,0$ is recommended.

**EJOT through bolt BA-V Plus/ BA-F Plus/
BA-E Plus /BA-E Plus HCR**

Performance

Characteristic shear resistance under fire exposure

Annex C4

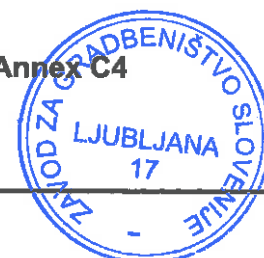

Table C5: Displacements under tension loads for static and quasi-static loading

EJOT through bolt BA-V Plus/ BA-F Plus/ BA-E Plus / BA-E Plus HCR			Anchor size				
			M8	M10- red	M10	M12-red	M12
Cracked C20/25 – C50/60	N	[kN]	4,05	4,3	5,7	6,1	7,6
	δ_{N0}	[mm]	0,981	0,494	0,619	0,541	0,241
	$\delta_{N=}$	[mm]	1,470	0,976	1,367	0,981	1,263
Non-cracked C20/25 - C50/60	N	[kN]	5,23	5,7	9,0	8,5	11,9
	δ_{N0}	[mm]	0,188	0,064	0,270	0,052	0,105
	$\delta_{N=}$	[mm]	1,470	0,976	1,367	0,981	1,263

Table C6: Displacements under shear loads for static and quasi-static loading

EJOT through bolt BA-V Plus/ BA-F Plus/ BA-E Plus / BA-E Plus HCR			Anchor size				
			M8	M10- red	M10	M12-red	M12
Cracked and non-cracked concrete C20/25 - C50/60	V	[kN]	6,9	10,3	10,3	16,0	16,0
	δ_{V0}	[mm]	1,600	1,925	0,884	3,522	2,023
	$\delta_{V=}$	[mm]	2,400	2,888	1,326	5,283	3,034

**EJOT through bolt BA-V Plus/ BA-F Plus/
BA-E Plus /BA-E Plus HCR**

Performance

Displacements under tension and shear loads

Annex C5

